

Magnetically Suspended Vacuum-Type Ultracentrifuge

J. W. Beams, J. D. Ross, and J. F. Dillon

Citation: *Review of Scientific Instruments* **22**, 77 (1951); doi: 10.1063/1.1745858

View online: <https://doi.org/10.1063/1.1745858>

View Table of Contents: <http://aip.scitation.org/toc/rsi/22/2>

Published by the *American Institute of Physics*



PFEIFFER VACUUM

VACUUM SOLUTIONS FROM A SINGLE SOURCE

Pfeiffer Vacuum stands for innovative and custom vacuum solutions worldwide, technological perfection, competent advice and reliable service.

[Learn more!](#)

The image shows a collection of Pfeiffer Vacuum products, including a red and silver rotary vane pump, a smaller red and silver pump, and a large industrial vacuum pump. The Pfeiffer Vacuum logo is prominently displayed at the top left of the advertisement.

Magnetically Suspended Vacuum-Type Ultracentrifuge*

J. W. BEAMS, J. D. ROSS, AND J. F. DILLON
University of Virginia, Charlottesville, Virginia

(Received September 20, 1950)

A centrifuge rotor constructed of steel and Duralumin ST-14 weighing 4.93 kilograms and having a radius of 65 mm to the center of the standard centrifuge cell, which contains the material to be centrifuged, is suspended magnetically in a high vacuum (pressure less than 10^{-6} mm Hg). The rotor is driven to running speed by an air turbine below the vacuum chamber. The turbine is connected to the rotor by a small steel shaft along the axis of rotation and passing through vacuum-tight oil glands into the vacuum chamber. When the rotor reaches operating speed, the shaft is disconnected and the rotor is allowed to coast freely during the sedimentation experiment. This is possible because of the very small deceleration of the rotor (less than a 0.1 revolution per sec per hour). As a result the temperature and rotor speed not only can be measured accurately, but can be maintained very nearly constant. The ultracentrifuge has been used both for rates of sedimentation measurements and for sedimentation equilibrium measurements, but is especially suited for the latter.

SINCE the pioneering work of Svedberg and his associates over thirty years ago, the analytical ultracentrifuge has been a most valuable tool for determining the molecular weights of high molecular weight substances.¹ In practice there are two general methods which make use of the ultracentrifuge for the determination of molecular weights or particle sizes. The first is known as the rate of sedimentation method and requires a centrifugal field large enough to produce an easily measurable rate of sedimentation. The second is known as the sedimentation equilibrium method and requires the centrifuging to continue long enough for the sedimentation to be balanced by back diffusion, i.e., until equilibrium is established. The first method usually requires at most only a few hours, while the second method may require several days of centrifuging. Each method has its special uses, but the theory employed by the second method is considered to be more reliable because it is based directly upon thermodynamics.¹

In both of the above methods the temperature and rotational speed not only must be known with precision but must be held as nearly constant as possible. Also, thermal gradients in the rotor or "hunting" in the rotor speed greatly reduce the reliability of the results obtained.^{1,2} This is especially true in the second or equilibrium method, where centrifuging must be continued for several days. The purpose of this paper is to describe a magnetically suspended vacuum type ultracentrifuge in which the rotor temperature and speed can be precisely determined. Also, thermal gradients and temperature changes of the rotor as well as "hunting" in the rotor speed are practically eliminated.

Figure 1 shows a scale drawing of the assembled apparatus and Fig. 2 a photograph with the vacuum chamber removed. The rotor *R* is freely suspended

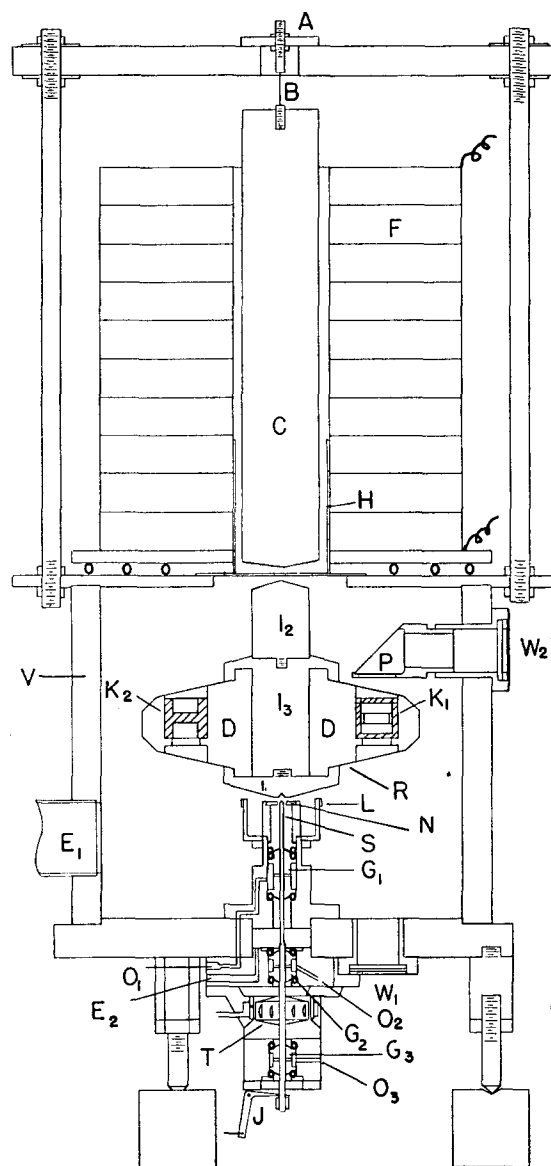

FIG. 1. Scale diagram of assembled ultracentrifuge.

* This work was supported by the Navy Bureau of Ordnance, Contract NOrd-7873.

¹ Svedberg and Pedersen, *The Ultracentrifuge* (Oxford University Press, 1940). (See for other references.)

² J. W. Beams, *Revs. Modern Phys.* **10**, 245 (1938); *J. Wash. Acad. Sci.* **37**, 221 (1947). (See for previous references.)

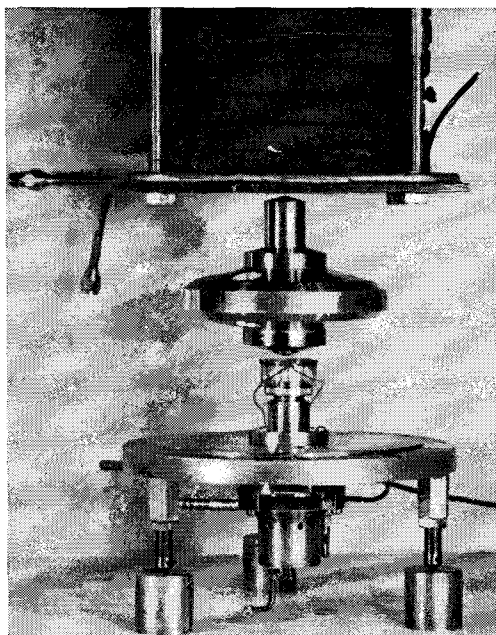

FIG. 2. Photograph of ultracentrifuge with vacuum chamber removed.

inside the brass vacuum chamber V by the solenoid F above the chamber and is accelerated to operating speed by the air turbine T below V . The shaft S which connects the air turbine with the rotor fits into a "screw driver slot," in the rotor and is disconnected and pulled down by the lever J when the rotor reaches the desired running speed. At operating speed the rotor is freely suspended and coasts without being driven during the period of observation of the sedimentation. The sedimentation is observed optically by passing a beam of light through the window W_1 , the centrifuge cell K_1 , the right angle prism P , and out through the window W_2 .

The rotor R is made up of three axially symmetrical pieces of high strength steel I_1 , I_2 , and I_3 surrounded by Duralumin ST 14 which extends to the periphery as shown in Fig. 1. I_1 , I_2 , and I_3 are assembled in such a way that they carry a part of the load and keep the Duralumin D from being overstressed. The bursting strength of a given shaped rotor is roughly determined by the magnitude of the ratio of the yield strength to the density of the material. This ratio is almost as large for Duralumin ST 14 as for steel, although it has a specific gravity of only 2.8 as compared with 7.8 for steel. On the other hand, the yield strength of steel is much higher than the Duralumin, so that by making the steel along the axis support the surrounding Duralumin, a strong rotor is obtained. Also, this construction confines the magnetic flux to regions along the axis of rotation. The cell K_1 carries the material to be centrifuged. It contains two crystal quartz windows separated by 5 mm. The cell is sector-shaped and has a

radial length of 15 mm. Its center is 65 mm from the axis of rotation. K_2 is a counter balance for K_1 . The construction of this cell is now standard and has been described in detail in the literature.^{3,4} The rotors used so far have circular cross sections except for the cell holes, but this is not necessary as long as the rotor is symmetrical around the axis. New rotors have been designed which should permit higher rotor speeds because the only factor that limits the angular speed is the bursting strength of the rotor.⁵ The rotor R in Fig. 1 weighs 4.93 kilograms and its moments of inertia about and perpendicular to the axis of rotation are approximately 10^5 g-cm² and 10^4 g-cm², respectively. The length of the steel cylinder I_2 is not critical and is determined by the size and position of the prism P .

The vacuum chamber V is made of brass because it should be nonmagnetic, and a good heat conductor. Its temperature is maintained at the desired value by circulating liquid through copper cooling tubes not shown in Fig. 1, except above the upper plate of the chamber. It should be noted that the part of the top of the vacuum chamber under the solenoid core C is made thin to cut down eddy currents when the current changes in F . The chamber V is evacuated through E_1 with an oil diffusion pump backed by a mechanical fore pump in series with dry ice and P_2O_5 traps. The pressure in the chamber is measured by an ionization gauge and must be kept well below 10^{-5} mm Hg.

The air turbine drive and oil glands G_1G_2 and G_3 are very similar to those we have used for several years and have described in detail elsewhere.^{2,3} G_1 , G_2 , and G_3 are Babbitt-lined brass bearings mounted in flexible Neoprene rings and are sealed by forcing oil through O_1 , O_2 , and O_3 . The oil in G_1 is low vapor pressure vacuum pump oil which is carefully dried and freed from air and other gases. The small chamber between G_1 and G_2 is evacuated through E_2 to below 10^{-2} mm of Hg by the fore pump. The shaft S ($\frac{1}{16}$ -in diameter inside the chamber) is a hard straight steel wire with the end which fits into the rotor R shaped like a flat bladed screw driver. It is easily ground by trial and error until it will stay connected to the rotor until the lever J pulls it down. The lever J is operated from outside a wooden barricade which surrounds the apparatus.

The support solenoid F consists of 28,000 turns of No. 22 enameled copper wire. Its resistance is 1200 ohms and its inductance about 70 henrys with the core C in place. The coil is wound in 10 flat pancakes, each one inch thick, i.d. $2\frac{5}{8}$ in, o.d. 9 in, and mounted rigidly. The above construction is not necessary, and an ordinary straight solenoid similar to those used for smaller rotors is probably as satisfactory.⁵ The operating current in the solenoid was usually between 150 and 220 milliamperes.

³ Beams, Linke, and Sommer, Rev. Sci. Instr. 18, 57 (1947).

⁴ E. G. Pickels, Rev. Sci. Instr. 13, 426 (1942).

⁵ Beams, Young, and Moore, J. Appl. Phys. 17, 886 (1946).

The soft steel cylindrical core *C* of the solenoid (diameter $1\frac{1}{8}$ in., length 12 in.) is suspended by a small wire *B* from an adjustable brass plate *A* as shown in Fig. 1. The lower end of *C* hangs in a cylindrical vessel *H* filled with No. 40 motor oil which damps any swinging motion. This arrangement is a modification of a method we have used for some time for damping any motion of the rotor perpendicular to the axis of rotation. It is very effective even for small rotors.⁶ *H* preferably should be made of nonmagnetic nonconducting material. The solenoid and core are thermally shielded from the top of the vacuum chamber by asbestos sheets and cooling coils as shown in Fig. 1.

The support circuit is shown in Fig. 3 and is an outgrowth of a development in this laboratory extending over several years.^{2, 5, 7-9} It consists of a three-megacycle tuned-grid tuned-plate oscillator, a cathode follower detector stage from which are derived a signal and its time derivative, a mixer stage that recombines these two signals, and a power stage, the load of which is the support solenoid *F*. The coil *L* in the grid circuit of the oscillator is situated just under the rotor (Fig. 1) and mounted on Lucite supports. It consists of 10 turns, 2 inches in diameter, of No. 20 enamel copper wire. The impedance of this coil is increased or decreased as the rotor moves up or down and hence, the tuning and amplitude of the oscillator depends upon the vertical position of the rotor. As a result, the circuit may be adjusted so that if the rotor rises, the current

in the solenoid *F* is decreased, and if it moves downward, the current in *F* is increased. These current changes are adjusted so that the rotor is maintained accurately in the desired vertical position without "hunting" about $\frac{1}{16}$ inch above the plane of the coil *L* and roughly $\frac{1}{8}$ inch below the top of the vacuum chamber, i.e., freely supported in the chamber. This is accomplished by introducing a derivative or "anti-hunt" signal hunt along with the error signal from *L*. When the circuit is properly adjusted, the vertical and horizontal stability of the freely suspended rotor is such that on motion can be observed with a 50-power microscope focused on scratches on the rotor. The power supplies for the circuit are standard commercial types with good regulations. Variations in the 110-volt laboratory power lines of as much as 15 volts did not affect the stability of the rotor.

The rotational speed of the rotor was determined by a standard photoelectric cell pick-up system. Some of the light from the beam passing through the cell *K*₁ fell upon the photo-cell. The signal produced was amplified and put on one pair of the plates of an oscilloscope. The other pair of oscilloscope plates were attached to a precision audiofrequency oscillator which was carefully calibrated before each reading by frequencies broadcast by the Bureau of Standards radio station WWV. A rotor speed was always selected so that it was near a fundamental or harmonic of the frequencies of WWV.

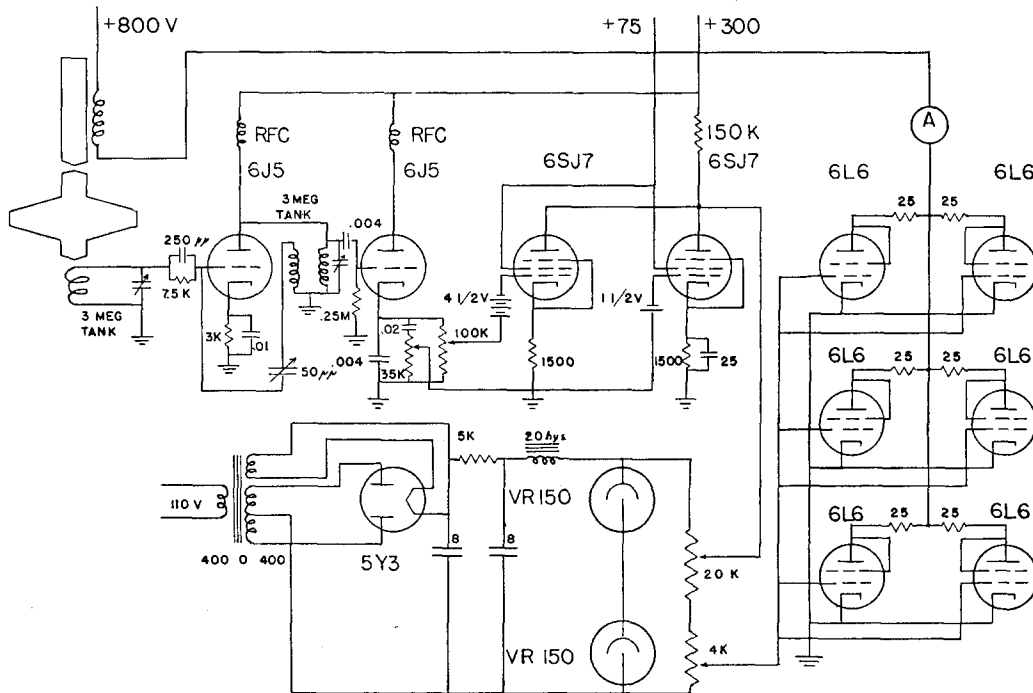

FIG. 3. Support circuit.

⁶ E. C. Smith and J. W. Beams, *Phys. Rev.* **79**, 222 (1950).
⁷ F. T. Holmes, *Rev. Sci. Instr.* **8**, 444 (1937).
⁸ F. T. Holmes and J. W. Beams, *Nature* **140**, 30 (1937).
⁹ L. E. MacHattie, *Rev. Sci. Instr.* **12**, 429 (1941).

In order to operate the centrifuge, the vacuum chamber is removed as shown in Fig. 2, and the circuits are adjusted until the rotor is stably supported. This circuit adjustment is not difficult and may be carried out as follows. With the rotor resting on N , the ring disk, and over the coil L , and the plate supply to the 6L6's switched off, the grid, plate, and neutralizing condensers are adjusted for maximum output as determined by a high resistance voltmeter in the detector circuit (200 to 250 volts). The neutralizing condenser is next adjusted until the voltmeter reads between 60 and 70 volts, care being taken that the oscillator continues to function with the rotor in its lowest position. The output should then increase as the rotor is raised further above the coil L . The plate voltage to the 6L6's is next turned on and the grid bias to the 6SJ7's and the differentiating condenser varied until the rotor is stably supported as determined by putting surges on the line. The circuit stays in adjustment indefinitely. The vacuum chamber V is next placed in position and the cell K_1 filled with the material to be centrifuged, sealed, and placed in the rotor, which in turn is placed on the flat brass ring support N surrounding the shaft. This disk ring support not only serves to hold the rotor while the solenoid is not in operation but is a safety catch for the rotor in case the power supply fails. The top plate of the chamber is next sealed on with vacuum wax and the solenoid and core mounted and adjusted. In the meantime, the electrical circuits have been allowed to warm up and the cooling fluid started circulating through the cooling coils attached to the chamber. The vacuum pumps are then started and the rotor is supported by the solenoid in its running position. The shaft S is next raised by hand and turned until it is attached to the rotor. When the pressure in the chamber is 10^{-6} mm of Hg or less, air at about 50 lbs/in² is admitted to the turbine T and the rotor is accelerated at the rate of about one rev/sec² until operating speed is reached. The lever J is next pulled to release the shaft S from the rotor. The rotor then continues to coast smoothly during the period of the experiment. In the meantime, the optical system for observing the sedimentation is put into adjustment.

When the pressure in the vacuum chamber is well below 10^{-6} mm of Hg, the rotor will coast without losing more than 0.1 revolution per sec per hour. In some previous experiments⁵ we have shown that the observed loss of speed could be accounted for entirely by air

friction on the rotor although no doubt there are extremely small losses due to the support. With this slow rate of deceleration the speed can of course be very accurately determined. Also the "hunting," which is often troublesome if the drive is irregular or when the power input to the rotor is large, is eliminated entirely in this experiment. With almost negligible air friction there is practically no heat generated on the rotor; and with no shaft to conduct heat to the rotor, its temperature must approach very closely to the temperature of the surrounding brass walls. Also, the conducting brass walls are insulated thermally on the outside with asbestos so that the cooling coils can keep them at a constant uniform temperature. The temperature was measured by shielded mercury thermometers in good thermal contact with the walls. After the experiment is completed, the rotor is brought down in speed by admitting some gas to the vacuum chamber. Hydrogen or helium is preferable, but air may be used. The only precaution required is to prevent overheating of the rotor.

The above centrifuge has been used for molecular weight determination by both the rate of sedimentation and by the sedimentation equilibrium methods. It was found to be particularly adapted to the latter method because of the long centrifuging time and the constancy of the speed and temperature required. The slight decrease in speed turns out not to disturb the equilibrium conditions in any way. With this equilibrium method the molecular weight M_e is given by the relation¹

$$M_e = 2RT \ln(C_1/C_2) / (1-dV) 4\pi^2 N^2 (r_1^2 - r_2^2),$$

where C_1 and C_2 are the concentrations at the radii r_1 and r_2 , respectively, T the absolute temperature, V the partial specific volume, d the density, and N the number of revolutions per sec. In the above experiments N could be measured to about one part in 10^6 and T to about one part in 10^4 , which is better than C_1 , C_2 , and V could be measured with reliability. N especially can be measured with much greater precision if necessary. Experiments are in progress to increase the precision of the determination of C_1 and C_2 , but there are some questions concerning the reliability of the standard methods of measuring V .^{1,10} However, the measurement of $M_e(1-dV)$ can be made with comparatively high precision with the above apparatus.

¹⁰ Bull. Physical Bio-Chemistry (John Wiley and Sons, Inc., New York, 1943).